

## D-LINE

# VD6.210

155 kW / 210 HP

DI diesel / 4 stroke / 6 cyl. in line  
turbo-charged / aftercooled  
common rail / EMR 3

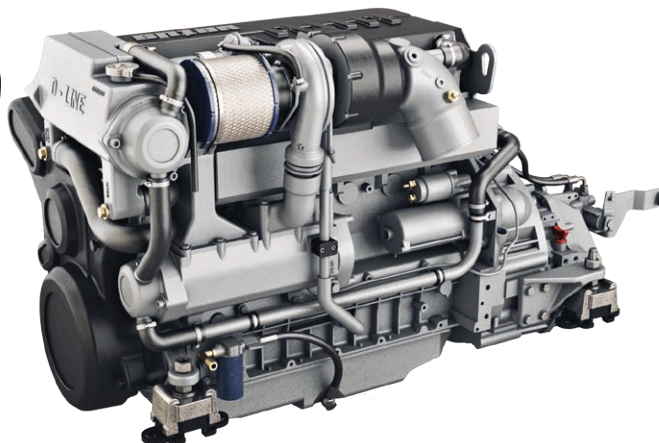

## TECHNICAL SPECIFICATIONS

Supplied as standard with instrument panel type MPA34BS2 (see page 103) and four flexible engine mountings type LMX210 (see page 49).

Engine model	VD6.210
CAN bus	SAE J1939
*Max. output at flywheel (ISO 8665)	155 kW (210 hp) (VD6.210)
*Max. output at propeller shaft (ISO 8665)	149 kW (203 hp) (VD6.210)
Maximum rpm	2400
Bore x stroke	101 mm x 126 mm
Capacity	6060 cm <sup>3</sup>
Number of cylinders	6 in line
Cooling system	intercooling
Compression ratio	18:1
Firing order	1-5-3-6-2-4
Alternator	12 Volt - 160 Amps. 24 Volt - 80 Amps.
Optional 2nd alternator	12 Volt - 160 Amps. 24 Volt - 80 Amps.
Torque	810 Nm / 1600 rpm
Idle speed	800 rpm
Fuel consumption at max. rpm	240 g / kW.h
Gearbox (standard)	ZF63
Ratio	1.51 / 1.93 / 2.48 / 2.78:1

Gearbox (optional)	ZF63A 1.22 / 1.56 / 2.04 / 2.52:1 ZF63IV 1.29 / 1.56 / 1.99 / 2.47:1
Dry weight (incl. standard gearbox)	657 kg
Fuel lift pump	1.5 m
Max. installation angle (backwards)	15°
Max. athwartship angle (continuously)	26°
Calorifier connection kit	optional
Electric oil drain pump	standard
P.T.O. flange to install hydr. pump	optional
Instrument panel	MPA34BS2
Instruments	Key switch, tacho meter/hour counter, volt meter, oil pressure gauge, temperature gauge
Acoustic alarm	Oil pressure, temperature, charging current fresh and raw water
Electric circuit protection	Resetable circuit breaker
Certification	2013/53/EU RCD II

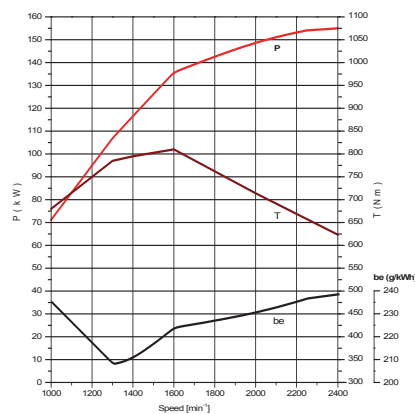
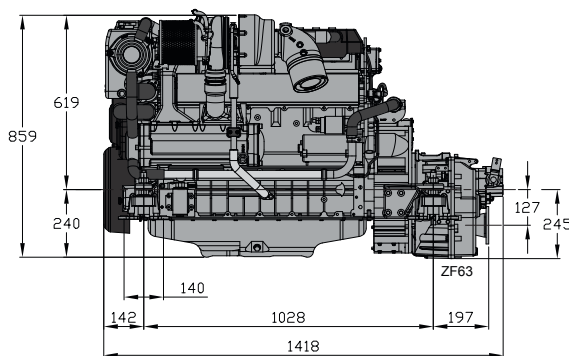
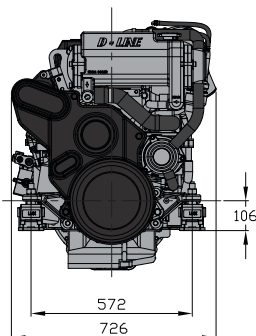

Certified within 5%