

**F-LINE**

# VF4.140

● ● ● ● 103 kW / 140 HP



## TECHNICAL SPECIFICATIONS

Supplied as standard with instrument panel type MPA34BS25 (see page 103) and including four flexible engine mountings.

Optional: Electric remote control type EC4 (see page 44).



All VETUS engines are certified according ISO 8178-1

Engine model	VF4.140C
Max. output at crank shaft (ISO 8665)	103 kW (140 hp)
Maximum rpm	4000
Bore x stroke	82 mm x 90,4 mm
Displacement	1910 cm <sup>3</sup>
Number of cylinders	4 in line
Configuration	4-stroke cycle, twin camshaft, 16 valves
Combustion system	Indirect injection
Intake	Turbo charged with variable geometry turbo
Electrical system	12 Volt - 115 Amps.
Starting system	Electric starting 14 Volt - 2.3 kW
Cooling system (standard)	indirect cooling

Lubrication system	Totally enclosed, forced lubricating system with pump
Gearbox (standard)	TM345(A)
Ratio	1.45 / 2 / 2.47:1
Gearbox options	ZF45 / ZF45A / ZF63IV 2 / 2.48:1
Sterndrive	Bravo I, II and III
Dry weight (incl. standard gearbox)	295 kg
Max. torque	310 Nm at 2200 rpm
Max. mounting inclination angle	10°
Instrument panel (standard)	MPA34BS25
Certifications	EU-RCD I

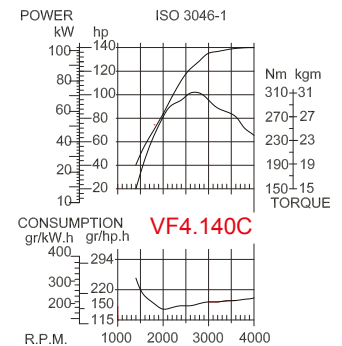
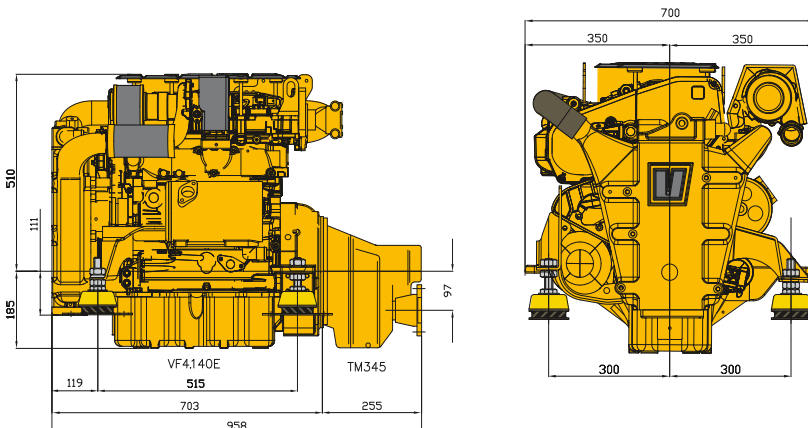

Certified within 5%

Drawing refers to gearbox version. Please ask for drawing of sterndrive version.