

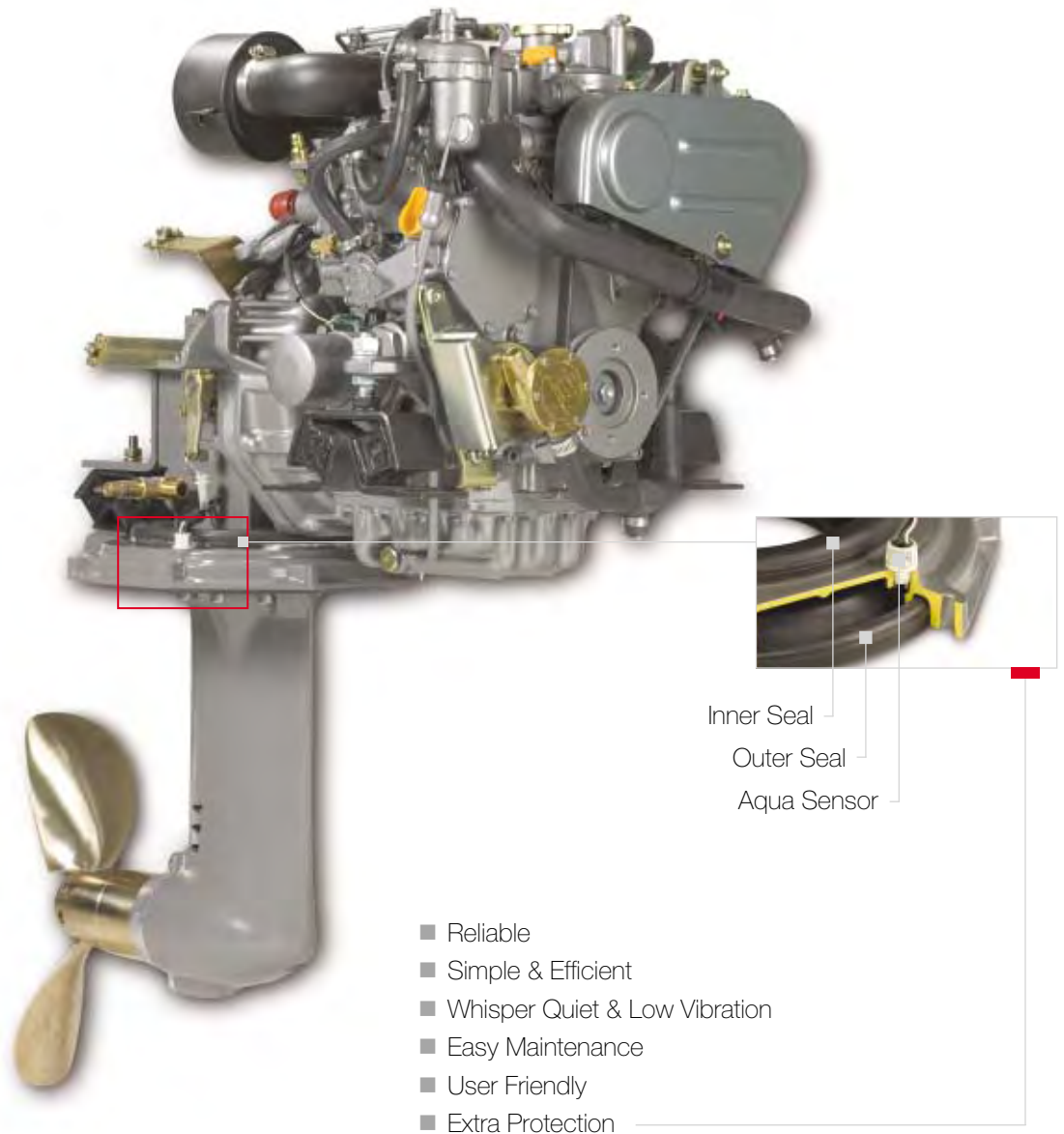

Yanmar Saildrive SD20

The Powerful Gem



- Reliable
- Simple & Efficient
- Whisper Quiet & Low Vibration
- Easy Maintenance
- User Friendly
- Extra Protection

Yanmar Saildrive Type	SD20
Reduction gear system	Constant mesh gear with dog clutch
Reduction ratio (fwd / asn)	2.64/2.64
Propeller speed (fwd / asn)	1287/1287 (for 1GM10), 1321/1321 (for YM series)
Direction of rotation (propeller shaft - fwd)	Counter clockwise viewed from stern
Dry weight Saildrive	30 kg (66 lbs)



Engine Model	1GM10C x SD20	2YM15C x SD20
Configuration	4-stroke, vertical, water cooled diesel engine	4-stroke, vertical, water cooled diesel engine
Maximum output at crankshaft	* 6.7 kW (9 hp) / 3600 rpm ** 6.6 kW (9 hp) / 3600 rpm	* 10.3 kW (14 hp) / 3600 rpm ** 10.0 kW (13.6 hp) / 3600 rpm
Continuous rating output at crankshaft	5.9 kW (8 hp) / 3400 rpm	9.4 kW (12.8 hp) / 3489 rpm
Displacement	0.318 L (19.41 cu in)	0.57 L (34.7 cu in)
Bore x stroke	75 mm x 72 mm (2.95 in x 2.83 in)	70 mm x 74 mm (2.75 in x 2.91 in)
Cylinders	1	2
Combustion system	Indirect injection	Indirect injection
Aspiration	Natural aspiration	Natural aspiration
Starting system	Electric starting with manual combination	Electric starting 12 V - 1.4 kW
Alternator	12 V - 35 A	12 V - 60 A (80 A optional)
Cooling system	Seawater cooling	Fresh water cooling
Lubrication system	Enclosed, forced lubricating system	Enclosed, forced lubricating system
Lubrication oil for Saildrive	API CC and SAE 10W30	API GL4 or GL5 and SAE 80W90 or 90
Direction of rotation (crankshaft)	Counter clockwise viewed from flywheel	Counter clockwise viewed from flywheel
Dry weight with Saildrive	104 kg (229 lbs)	134 kg (295 lbs)
Environmental	Will meet the comprehensive emissions regulations to be introduced in EU and US Tier 2 in 2006	
Engine mounting	Rubber type flexible mounting	

NOTE: Fuel condition: Density at 15°C = 0.842 g / cm³; 1 hp = 0.7355 kW

* Fuel temperature 25°C at the inlet of the fuel injection pump (ISO 3046-1)

** Fuel temperature 40°C at the inlet of the fuel injection pump (ISO 8665)

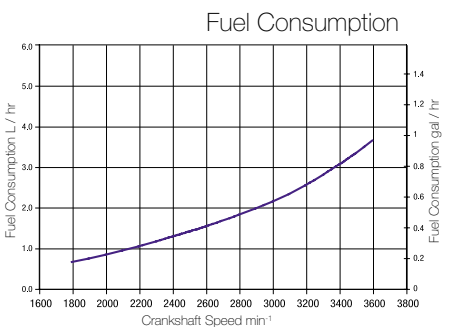
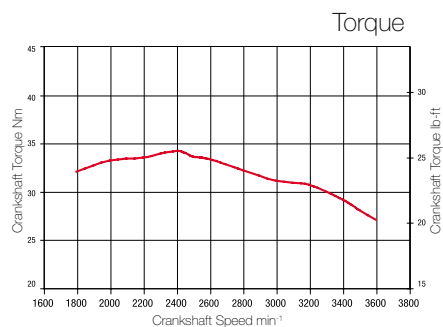
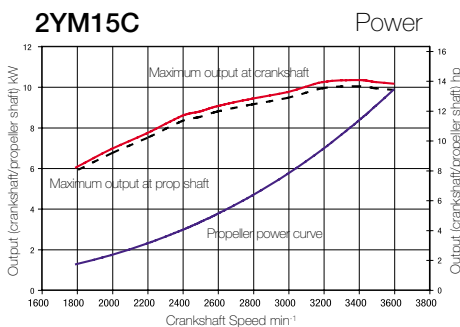
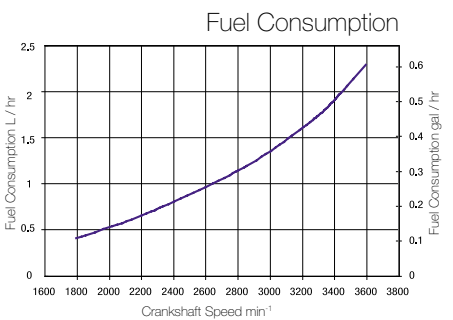
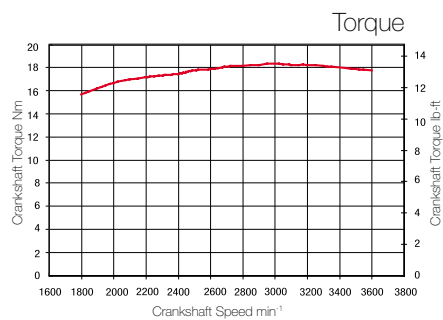
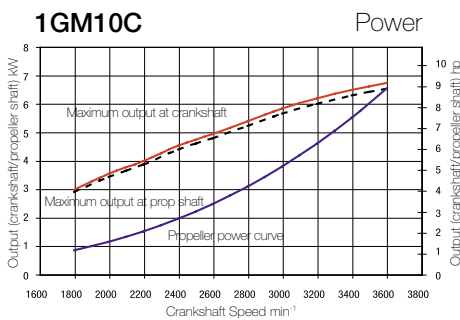



3YM20C x SD20

4-stroke, vertical, water cooled diesel engine

* 16.2 kW (22 hp) / 3600 rpm
 ** 15.3 kW (21 hp) / 3600 rpm

14.7 kW (20 hp) / 3489 rpm

0.854 L (52.1 cu in)

70 mm x 74 mm (2.8 in x 2.9 in)

3

Indirect injection

Natural aspiration

Electric starting 12 V - 1.4 kW

12 V - 60 A (80 A optional)

Fresh water cooling

Enclosed, forced lubricating system

API GL4 or GL5 and SAE 80W90 or 90

Counter clockwise viewed from flywheel

151 kg (333 lbs)

3YM30C x SD20

4-stroke, vertical, water cooled diesel engine

* 22.1 kW (30 hp) / 3600 rpm
 ** 21.3 kW (29.1 hp) / 3600 rpm

20.1 kW (27.3 hp) / 3489 rpm

1.115 L (68 cu in)

76 mm x 82 mm (2.9 in x 3.2 in)

3

Indirect injection

Natural aspiration

Electric starting 12 V - 1.4 kW

12 V - 60 A (80 A optional)

Fresh water cooling

Enclosed, forced lubricating system

API GL4 or GL5 and SAE 80W90 or 90

Counter clockwise viewed from flywheel

157 kg (346 lbs)

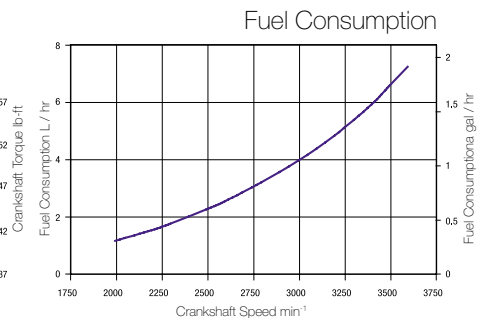
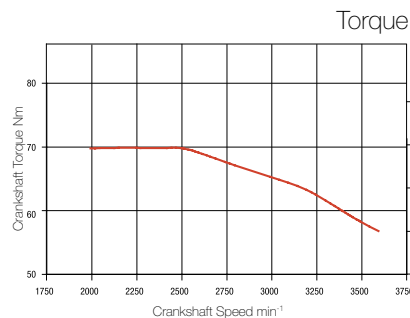
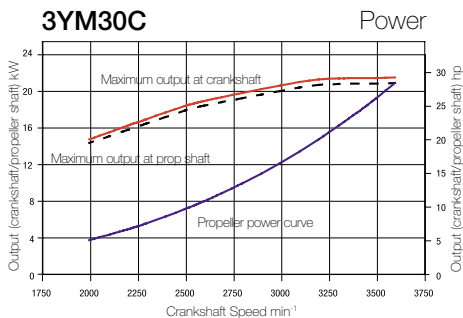
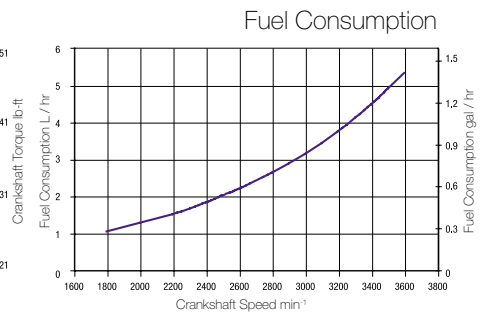
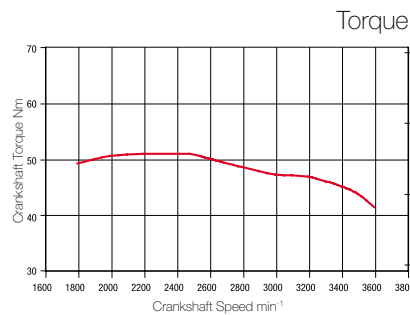
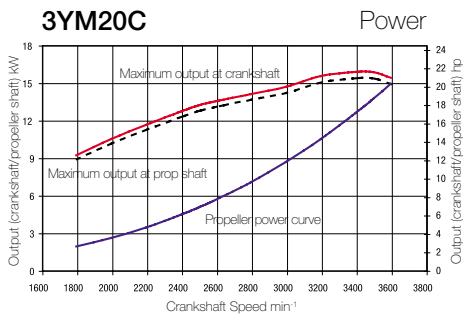

1GM10C

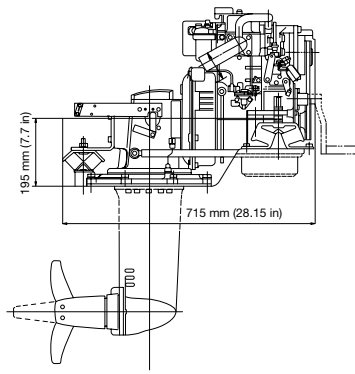
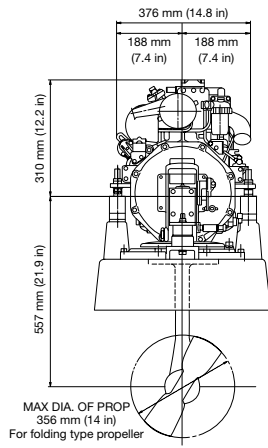

2YM15C

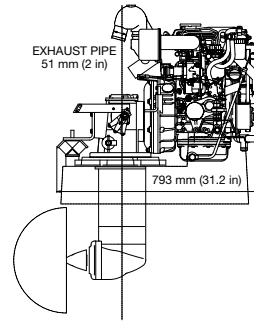
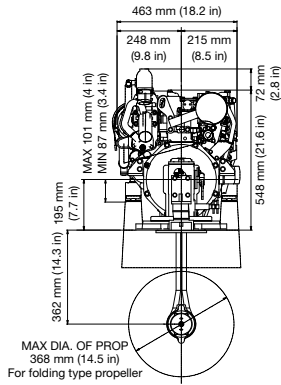

3YM20C

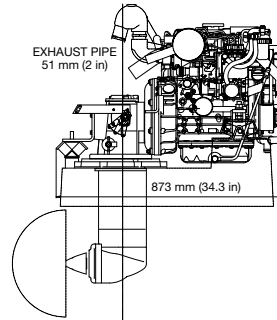
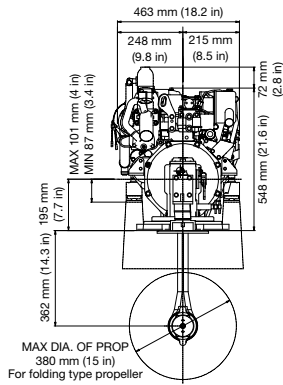

3YM30C

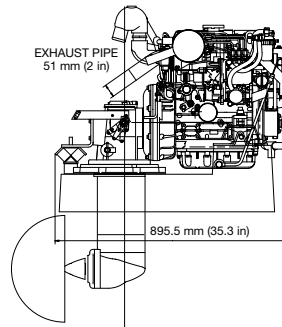
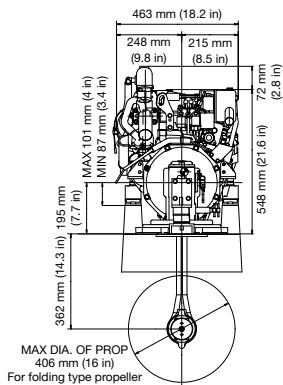

Yanmar Marine International B.V.
 Brugplein 11
 1332 BS Almere-de Vaart
 The Netherlands

Yanmar Marine USA Corp.
 101 International Parkway
 Adairsville,
 Georgia 30103
 USA

Yanmar Asia (Singapore) PTE
 4 Tuas Lane
 Singapore 638613

Yanmar Co., LTD
 5-3-1 Tsukagachi - Honmachi
 Amagasaki
 Japan

2005 Yanmar Marine®, Inc. All rights reserved, Printed in EC

www.yanmarmarine.com

